

DIRECT SET FIXED WOOD WINDOW

DESIGN LOAD RATINGS FOR THESE WINDOWS TO BE AS PER CHARTS SHOWN ON SHEET 3.

APPROVAL APPLIES TO SINGLE UNITS OR SIDE BY SIDE COMBINATIONS OF FIXED/FIXED OR FIXED WITH OTHER WINDOW TYPES IN MODULES OF TWO OR MORE WINDOWS USING F.B.C. APPROVED MULLIONS IN BETWEEN.

LOWER DESIGN PRESSURE FROM WINDOWS CAPACITY CHART OR MULLION APPROVAL WILL APPLY TO ENTIRE SYSTEM.

THIS PRODUCT HAS BEEN DESIGNED AND TESTED TO COMPLY WITH THE REQUIREMENTS OF THE 2020 (7TH EDITION) FLORIDA BUILDING CODE INCLUDING HIGH VELOCITY HURRICANE ZONE (HVHZ).

1BY OR 2BY WOOD BUCKS & BUCK FASTENERS BY OTHERS, MUST BE DESIGNED AND INSTALLED ADEQUATELY TO TRANSFER APPLIED PRODUCT LOADS TO THE BUILDING STRUCTURE.

ANCHORS SHALL BE CORROSION RESISTANT, SPACED AS SHOWN ON DETAILS AND INSTALLED PER MANUF'S INSTRUCTIONS. SPECIFIED EMBEDMENT TO BASE MATERIAL SHALL BE BEYOND WALL DRESSING OR STUCCO.

A LOAD DURATION INCREASE IS USED IN DESIGN OF ANCHORS INTO WOOD ONLY.

ALL SHIMS TO BE HIGH IMPACT, NON-METALLIC AND NON-COMPRESSIBLE.

MATERIALS INCLUDING BUT NOT LIMITED TO STEEL/METAL SCREWS, THAT COME INTO CONTACT WITH OTHER DISSIMILAR MATERIALS SHALL MEET THE REQUIREMENTS OF THE 2020 FLORIDA BLDG. CODE & ADOPTED STANDARDS.

THIS PRODUCT APPROVAL IS GENERIC AND DOES NOT PROVIDE INFORMATION FOR A SITE SPECIFIC PROJECT, i.e. LIFE SAFETY OF THIS PRODUCT, ADEQUACY OF STRUCTURE RECEIVING THIS PRODUCT AND SEALING AROUND OPENING FOR WATER INFILTRATION RESISTANCE ETC.

CONDITIONS NOT SHOWN IN THIS DRAWING ARE TO BE ANALYZED SEPARATELY, AND TO BE REVIEWED BY BUILDING OFFICIAL.

DESIGN LOADS SHOWN ARE BASED ON 'ALLOWABLE STRESS DESIGN (ASD)'. MANUFACTURER'S LABEL SHALL BE LOCATED ON A READILY VISIBLE LOCATION IN ACCORDANCE WITH SECTION 1709.9.3 OF FLORIDA BUILDING CODE.

LABELING TO COMPLY WITH SECTION 1709.9.2.

WINDOWS COMPLY WITH REQUIREMENTS OF ANSI Z97.1.

THESE WINDOWS ARE RATED FOR LARGE & SMALL MISSILE IMPACT. SHUTTERS ARE NOT REQUIRED.

Sealed: 6/27/2022

FL #41587

- A- CONTRACTOR TO BE RESPONSIBLE FOR THE SELECTION, PURCHASE AND INSTALLATION OF THIS PRODUCT BASED ON THIS PRODUCT EVALUATION PROVIDED HE/SHE DOES NOT DEVIATE FROM THE CONDITIONS DETAILED ON THIS DOCUMENT.
- B- THIS PRODUCT EVALUATION DOCUMENT WILL BE CONSIDERED INVALID IF ALTERED BY ANY MEANS.
- C- SITE SPECIFIC PROJECTS SHALL BE PREPARED BY A FLORIDA REGISTERED ENGINEER OR ARCHITECT WHICH WILL BECOME THE ENGINEER OF RECORD (E.O.R.) FOR THE PROJECT AND WHO WILL BE RESPONSIBLE FOR THE PROPER USE OF THE P.E.D. ENGINEER OF RECORD, ACTING AS A DELEGATED ENGINEER TO THE P.E.D. ENGINEER SHALL SUBMIT TO THIS LATTER THE SITE SPECIFIC DRAWINGS FOR REVIEW.
- D- THIS P.E.D. SHALL BEAR THE DATE AND ORIGINAL SEAL AND SIGNATURE OF THE PROFESSIONAL ENGINEER OF RECORD THAT PREPARED IT.

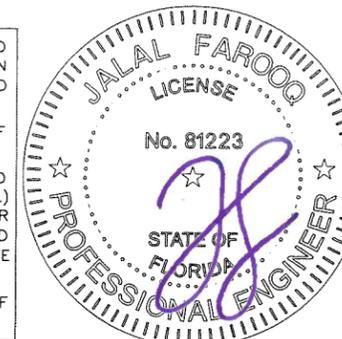

AL-FAROOQ CORPORATION
 ENGINEERS & PRODUCT DEVELOPMENT
 9360 SUNSET DRIVE, SUITE 220
 MIAMI, FLORIDA 33173 (C.A.N. 3538)
 TEL. (305) 264-8100 FAX. (305) 262-6978

DIRECT SET FIXED WOOD WINDOW (L.M.I.)
Exclusive Wood Doors, Inc.
 2000 N.W. 95Th Ave.
 Doral, FL. 33172
 Tel. (305) 477-2278 Fax. (305) 477-7140

| | | | | |
|--------------------|----------|--------|----|---------------|
| revisions: | no. | date | by | description |
| | | | | |
| date: | 06-06-22 | scale: | - | dr. by: TARIQ |
| | | | | chk. by: |
| drawing no. 22-19F | | | | |
| sheet 1 of 9 | | | | |

COMP-ANL\22-19F-EWD

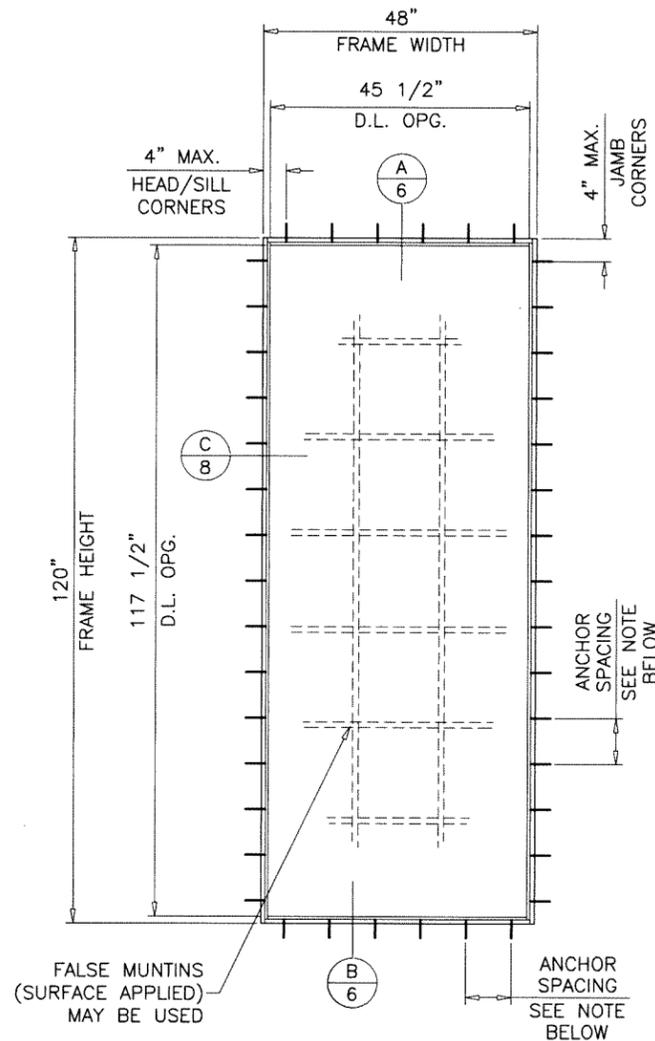

TYPICAL ELEVATION
(1-1/4" FRAMES)

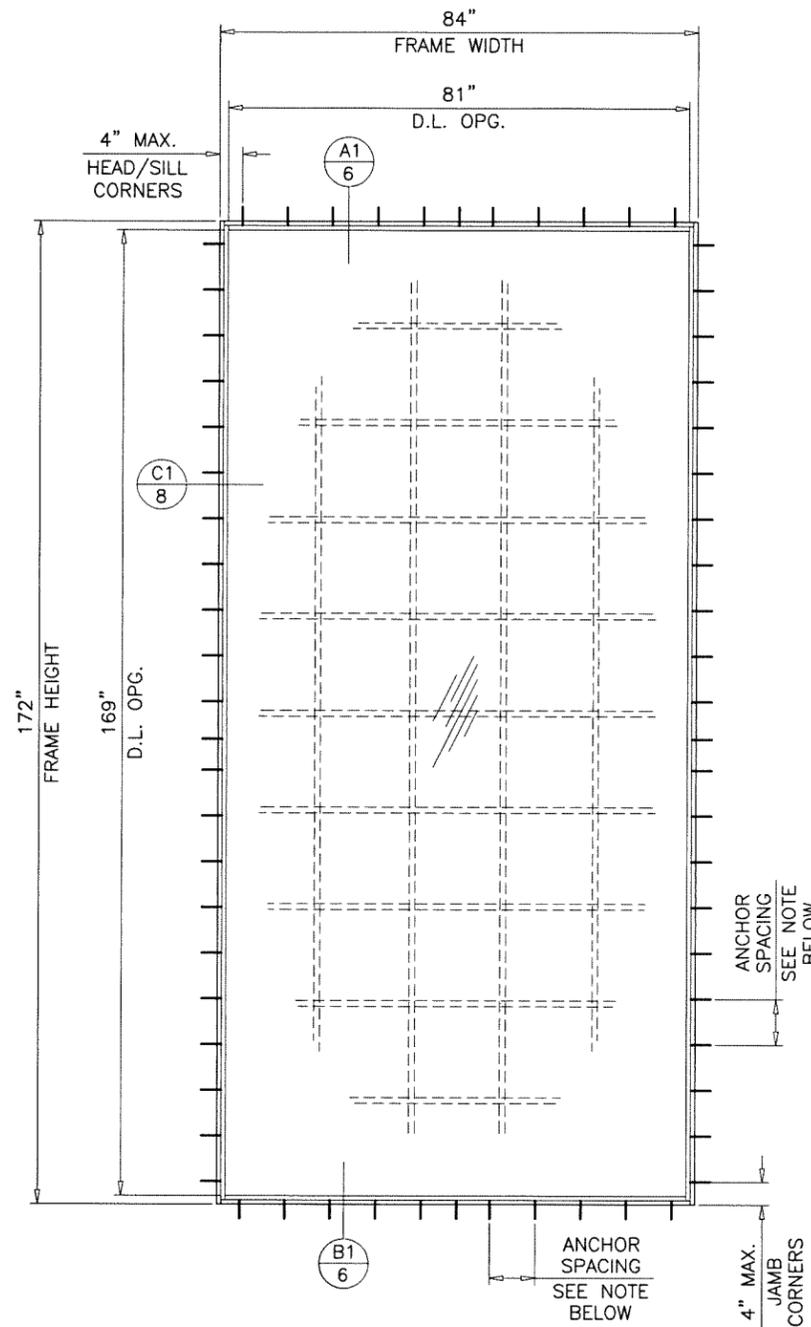

TYPICAL ELEVATION
(1-1/2" FRAMES)

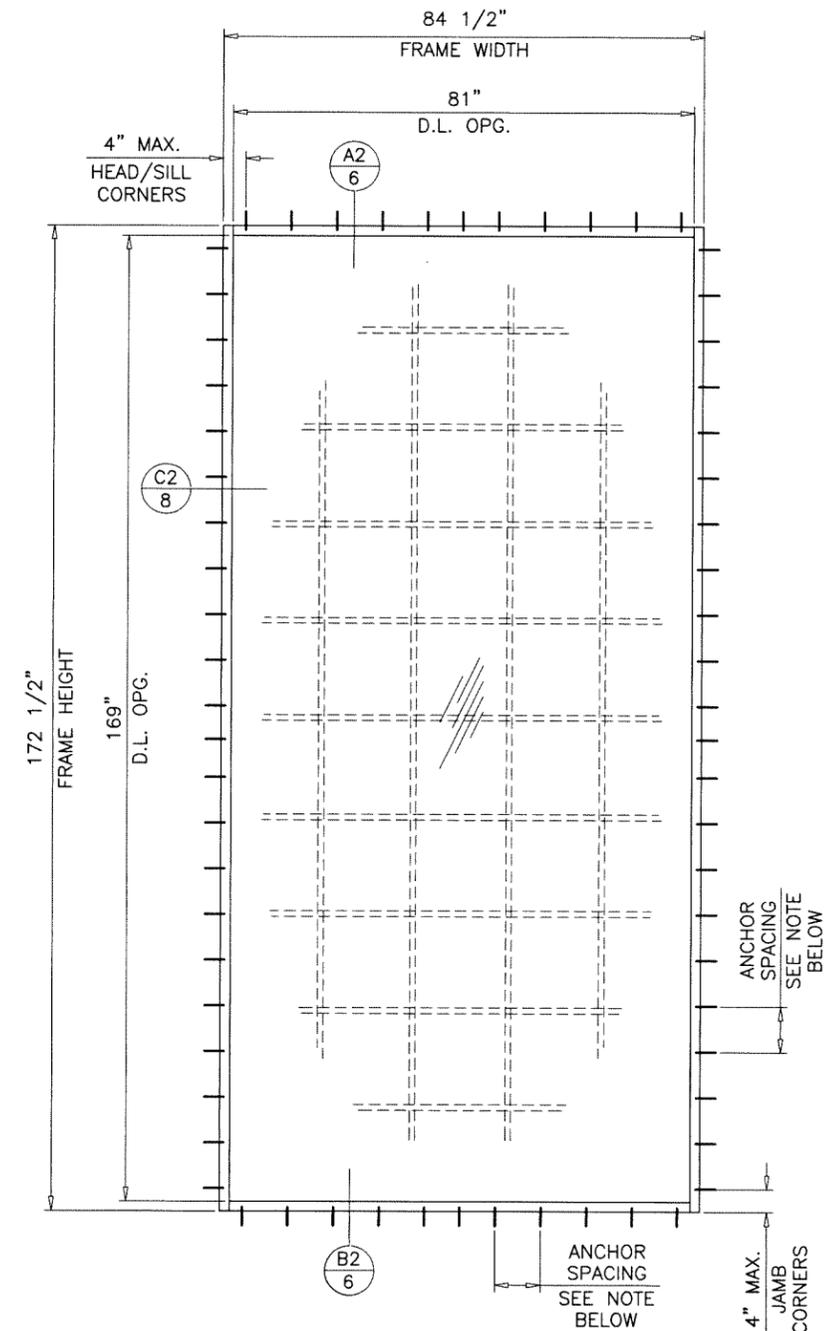

TYPICAL ELEVATION
(1-3/4" FRAMES)

FRAME ANCHOR SPACING:
 12" O.C. MAX. FOR ANCHORS TYPE 'A'
 10" O.C. MAX. FOR ANCHORS TYPE 'B'
 8" O.C. MAX. FOR ANCHORS TYPE 'C'

GLASS D.L.O. FORMULAE:

- D.L.O. WIDTH (1-1/4" FRAMES) = FRAME WIDTH - 2.50"
- D.L.O. HEIGHT (1-1/4" FRAMES) = FRAME HEIGHT - 2.50"
- D.L.O. WIDTH (1-1/2" FRAMES) = FRAME WIDTH - 3.0"
- D.L.O. HEIGHT (1-1/2" FRAMES) = FRAME HEIGHT - 3.0"
- D.L.O. WIDTH (1-3/4" FRAMES) = FRAME WIDTH - 3.50"
- D.L.O. HEIGHT (1-3/4" FRAMES) = FRAME HEIGHT - 3.50"



Sealed: 6/27/2022

FL #41587

af c
AL-FAROOQ CORPORATION
 ENGINEERS & PRODUCT DEVELOPMENT
 9360 SUNSET DRIVE, SUITE 220 (C.A.N. 3538)
 MIAMI, FLORIDA 33173 TEL. (305) 262-6978
 TEL. (305) 264-8100 FAX. (305) 262-6978
 COMP-ANL 22-19F-EWD

DIRECT SET FIXED WOOD WINDOW (L.M.I.)

Exclusive Wood Doors, Inc.

2000 N.W. 95Th Ave.
 Doral, FL 33172

Tel. (305) 477-2278 Fax. (305) 477-7140

| no | date | by | description |
|----|------|----|-------------|
| | | | |
| | | | |
| | | | |

date: 06-06-22
 scale: 3/8"=1'-0"
 dr. by: TARIQ
 chk. by:

drawing no.

22-19F

sheet 2 of 9

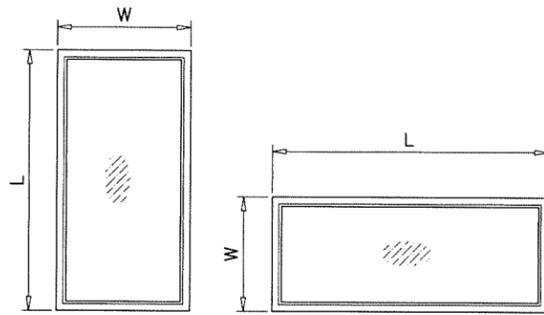

NOTE:
WIDTH AND LENGTH DIMENSIONS CAN BE ORIENTED
VERTICALLY OR HORIZONTALLY AS SHOWN ABOVE.

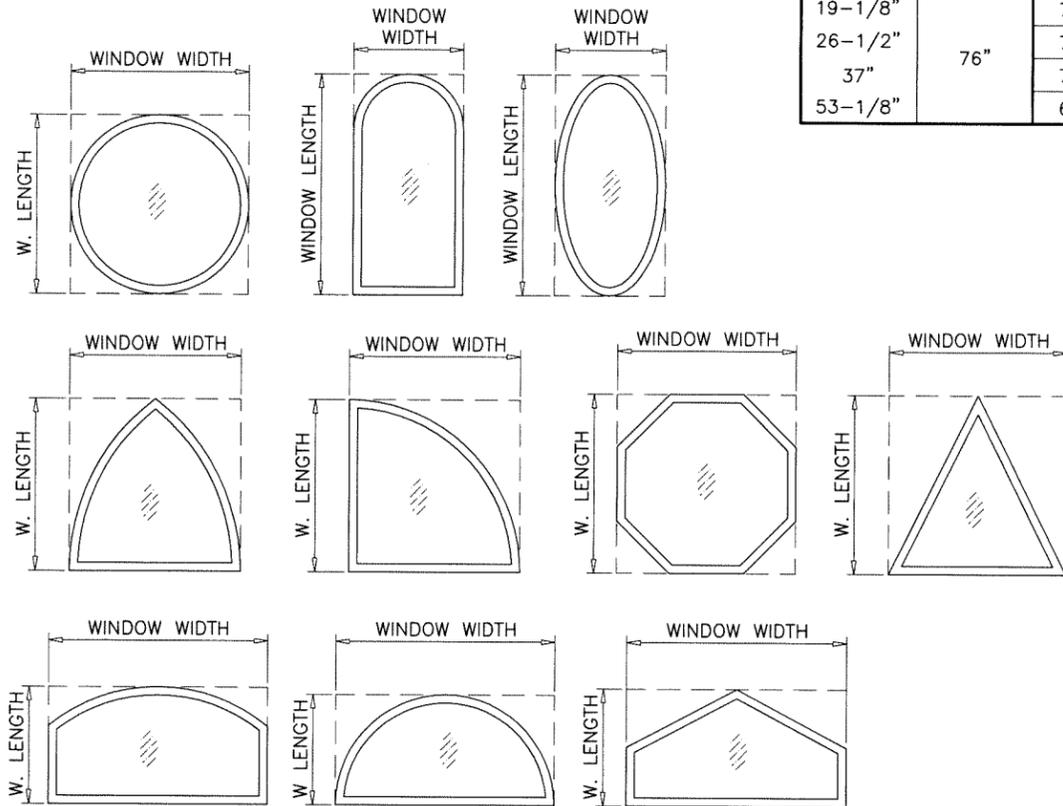

ALLOWABLE LOADS FOR ALTERNATE SHAPES AS SHOWN ABOVE OR SIMILAR CAN BE
VERIFIED BY INSCRIBING PICTURE WINDOW SHAPE WITHIN SQUARE OR RECTANGLE AS
SHOWN IN DOTTED LINES AND OBTAINING ALLOWABLE LOADS FROM THOSE SHAPES.

DESIGN LOAD CAPACITY - PSF
1-1/4", 1-1/2" & 1-3/4" FRAMES

| FRAME DIMS. | | GLASS TYPES 'A' & 'Ai' | |
|-------------|---------|---------------------------|---------|
| WIDTH | HEIGHT | EXT.(+) | INT.(-) |
| 19-1/8" | 26" | 70.0 | 70.0 |
| 26-1/2" | | 70.0 | 70.0 |
| 37" | | 70.0 | 70.0 |
| 53-1/8" | | 70.0 | 70.0 |
| 19-1/8" | 38-3/8" | 70.0 | 70.0 |
| 26-1/2" | | 70.0 | 70.0 |
| 37" | | 70.0 | 70.0 |
| 53-1/8" | | 70.0 | 70.0 |
| 19-1/8" | 50-5/8" | 70.0 | 70.0 |
| 26-1/2" | | 70.0 | 70.0 |
| 37" | | 70.0 | 70.0 |
| 53-1/8" | | 66.4 | 66.4 |
| 19-1/8" | 56" | 70.0 | 70.0 |
| 26-1/2" | | 70.0 | 70.0 |
| 37" | | 70.0 | 70.0 |
| 53-1/8" | | 63.2 | 63.2 |
| 19-1/8" | 63" | 70.0 | 70.0 |
| 26-1/2" | | 70.0 | 70.0 |
| 37" | | 70.0 | 70.0 |
| 53-1/8" | | 63.2 | 63.2 |
| 19-1/8" | 72" | 70.0 | 70.0 |
| 26-1/2" | | 70.0 | 70.0 |
| 37" | | 70.0 | 70.0 |
| 53-1/8" | | 63.2 | 63.2 |
| 19-1/8" | 76" | 70.0 | 70.0 |
| 26-1/2" | | 70.0 | 70.0 |
| 37" | | 70.0 | 70.0 |
| 53-1/8" | | 63.2 | 63.2 |

DESIGN LOAD CAPACITY - PSF
1-1/2" & 1-3/4" FRAMES

| FRAME DIMS. | | GLASS TYPES 'B' & 'Bi' | |
|-------------|---------|---------------------------|---------|
| WIDTH | HEIGHT | EXT.(+) | INT.(-) |
| 19-1/8" | 26" | 70.0 | 70.0 |
| 26-1/2" | | 70.0 | 70.0 |
| 37" | | 70.0 | 70.0 |
| 53-1/8" | | 70.0 | 70.0 |
| 19-1/8" | 38-3/8" | 70.0 | 70.0 |
| 26-1/2" | | 70.0 | 70.0 |
| 37" | | 70.0 | 70.0 |
| 53-1/8" | | 70.0 | 70.0 |
| 19-1/8" | 50-5/8" | 70.0 | 70.0 |
| 26-1/2" | | 70.0 | 70.0 |
| 37" | | 70.0 | 70.0 |
| 53-1/8" | | 70.0 | 70.0 |
| 19-1/8" | 56" | 70.0 | 70.0 |
| 26-1/2" | | 70.0 | 70.0 |
| 37" | | 70.0 | 70.0 |
| 53-1/8" | | 70.0 | 70.0 |
| 19-1/8" | 63" | 70.0 | 70.0 |
| 26-1/2" | | 70.0 | 70.0 |
| 37" | | 70.0 | 70.0 |
| 53-1/8" | | 70.0 | 70.0 |
| 19-1/8" | 72" | 70.0 | 70.0 |
| 26-1/2" | | 70.0 | 70.0 |
| 37" | | 70.0 | 70.0 |
| 53-1/8" | | 70.0 | 70.0 |
| 19-1/8" | 76" | 70.0 | 70.0 |
| 26-1/2" | | 70.0 | 70.0 |
| 37" | | 70.0 | 70.0 |
| 53-1/8" | | 70.0 | 70.0 |

DESIGN LOAD CAPACITY - PSF
1-1/4", 1-1/2" & 1-3/4" FRAMES

| FRAME DIMS. | | GLASS TYPES 'A' & 'Ai' | |
|-------------|--------|---------------------------|---------|
| WIDTH | HEIGHT | EXT.(+) | INT.(-) |
| 36" | 72" | 70.0 | 70.0 |
| 42" | | 70.0 | 70.0 |
| 48" | | 70.0 | 70.0 |
| 54" | | 62.2 | 62.2 |
| 60" | | 56.0 | 56.0 |
| 66" | | 50.9 | 50.9 |
| 72" | 46.7 | 46.7 | |
| 36" | 84" | 70.0 | 70.0 |
| 42" | | 70.0 | 70.0 |
| 48" | | 70.0 | 70.0 |
| 54" | | 62.2 | 62.2 |
| 60" | | 56.0 | 56.0 |
| 66" | | 50.9 | 50.9 |
| 36" | 96" | 70.0 | 70.0 |
| 42" | | 70.0 | 70.0 |
| 48" | | 70.0 | 70.0 |
| 54" | | 62.2 | 62.2 |
| 60" | | 56.0 | 56.0 |
| 66" | | 50.9 | 50.9 |
| 36" | 120" | 70.0 | 70.0 |
| 42" | | 70.0 | 70.0 |
| 48" | | 70.0 | 70.0 |
| 54" | | 62.2 | 62.2 |
| 60" | | 56.0 | 56.0 |
| 66" | | 50.9 | 50.9 |
| 36" | 132" | 70.0 | 70.0 |
| 42" | | 70.0 | 70.0 |
| 48" | | 70.0 | 70.0 |
| 54" | | 62.2 | 62.2 |
| 60" | | 56.0 | 56.0 |
| 66" | | 50.9 | 50.9 |
| 36" | 156" | 70.0 | 70.0 |
| 42" | | 70.0 | 70.0 |
| 48" | | 70.0 | 70.0 |
| 54" | | 62.2 | 62.2 |
| 60" | | 56.0 | 56.0 |
| 66" | | 50.9 | 50.9 |

DESIGN LOAD CAPACITY - PSF
1-1/2" & 1-3/4" FRAMES

| FRAME DIMS. | | GLASS TYPES 'B' & 'Bi' | | |
|-------------|--------|---------------------------|---------|------|
| WIDTH | HEIGHT | EXT.(+) | INT.(-) | |
| 66" | 120" | 70.0 | 70.0 | |
| 72" | | 70.0 | 70.0 | |
| 78" | | 70.0 | 70.0 | |
| 84" | | 70.0 | 70.0 | |
| 90" | | 65.3 | 65.3 | |
| 96" | | 61.3 | 61.3 | |
| 102" | 57.6 | 57.6 | | |
| 108" | 54.4 | 54.4 | | |
| 114" | 51.6 | 51.6 | | |
| 120" | 49.0 | 49.0 | | |
| 66" | 132" | 70.0 | 70.0 | |
| 72" | | 70.0 | 70.0 | |
| 78" | | 70.0 | 70.0 | |
| 84" | | 70.0 | 70.0 | |
| 90" | | 65.3 | 65.3 | |
| 96" | | 61.3 | 61.3 | |
| 102" | 57.6 | 57.6 | | |
| 108" | 54.4 | 54.4 | | |
| 66" | 144" | 70.0 | 70.0 | |
| 72" | | 70.0 | 70.0 | |
| 78" | | 70.0 | 70.0 | |
| 84" | | 70.0 | 70.0 | |
| 90" | | 65.3 | 65.3 | |
| 96" | | 61.3 | 61.3 | |
| 66" | 156" | 70.0 | 70.0 | |
| 72" | | 70.0 | 70.0 | |
| 78" | | 70.0 | 70.0 | |
| 84" | | 70.0 | 70.0 | |
| 90" | | 65.3 | 65.3 | |
| 96" | | 61.3 | 61.3 | |
| 66" | 172" | 70.0 | 70.0 | |
| 72" | | 70.0 | 70.0 | |
| 78" | | 70.0 | 70.0 | |
| 84" | | 70.0 | 70.0 | |
| 66" | | 180" | 70.0 | 70.0 |
| 72" | | | 70.0 | 70.0 |
| 78" | 70.0 | | 70.0 | |

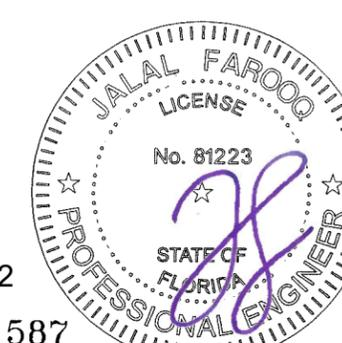

Sealed: 6/27/2022

FL #41587

AL-FAROOQ CORPORATION
ENGINEERS & PRODUCT DEVELOPMENT
9360 SUNSET DRIVE, SUITE 220
MIAMI, FLORIDA 33173
TEL. (305) 262-6978
FAX. (305) 264-8100
C.A.N. 3538

DIRECT SET FIXED WOOD WINDOW (L.M.I.)
Exclusive Wood Doors, Inc.
2000 N.W. 95Th Ave.
Doral, FL. 33172
Tel. (305) 477-2278 Fax. (305) 477-7140

| | | | | |
|-------------|----------|----------|----|-------------|
| revisions: | no | date | by | description |
| date: | 06-06-22 | scale: | - | |
| dr. by: | TARIQ | chk. by: | | |
| drawing no. | 22-19F | | | |
| sheet | 3 of 9 | | | |

COMP-ANL 22-19F-EWD

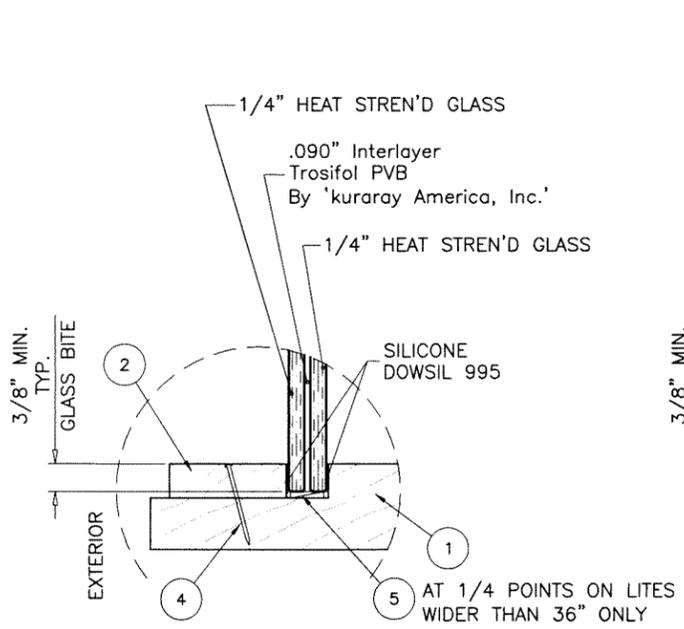

GLASS TYPE 'A'
9/16" OVERALL LAM. GLASS

1-1/4" FRAMES

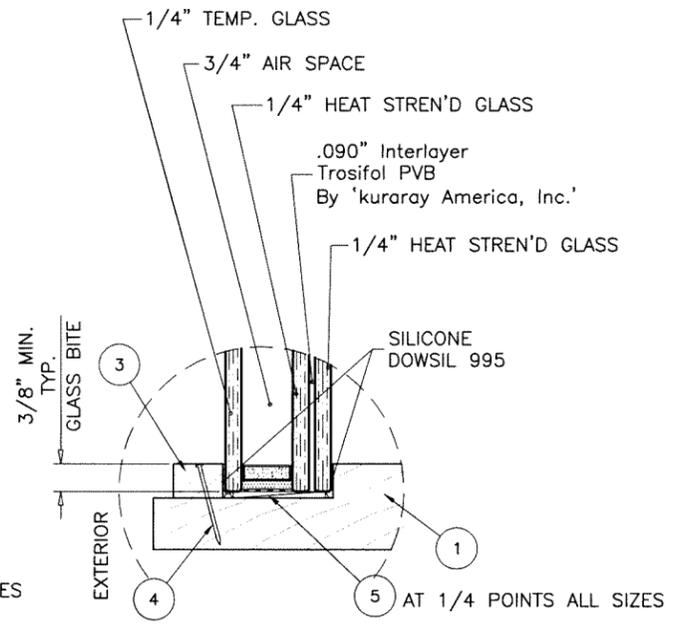

GLASS TYPE 'Ai'
1-1/2" OVERALL INSUL. LAM. GLASS

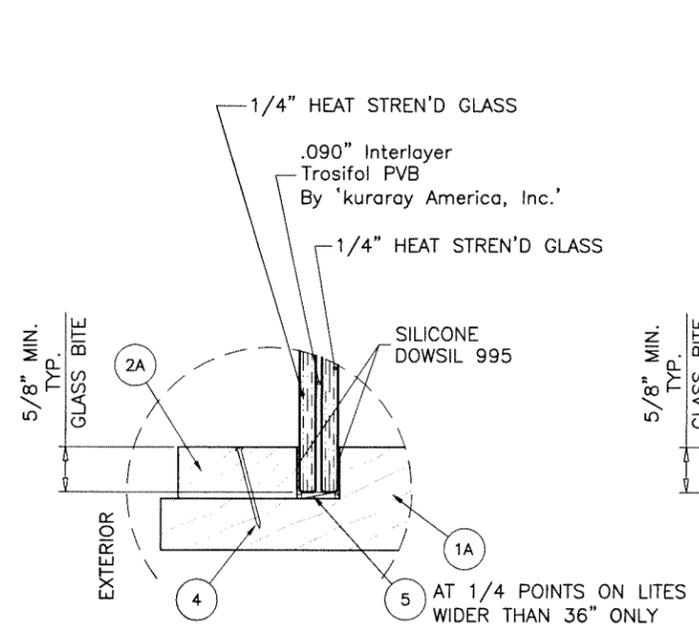

GLASS TYPE 'A'
9/16" OVERALL LAM. GLASS

1-1/2" FRAMES

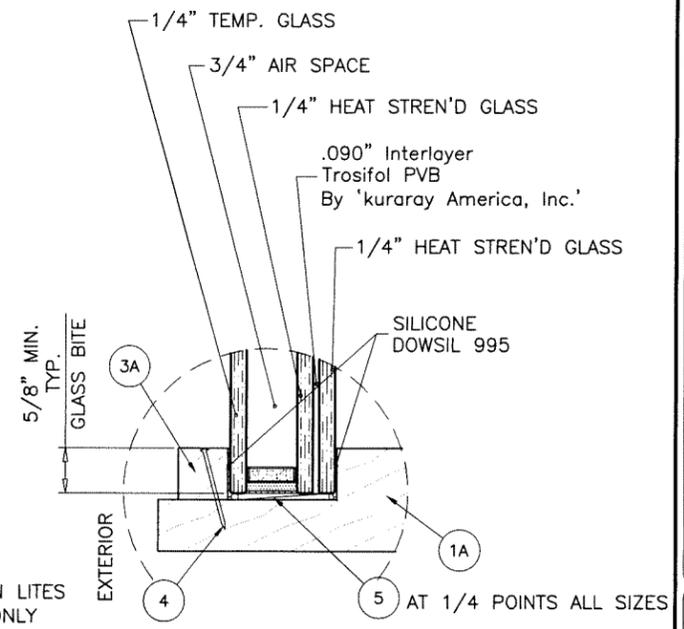

GLASS TYPE 'Ai'
1-1/2" OVERALL INSUL. LAM. GLASS

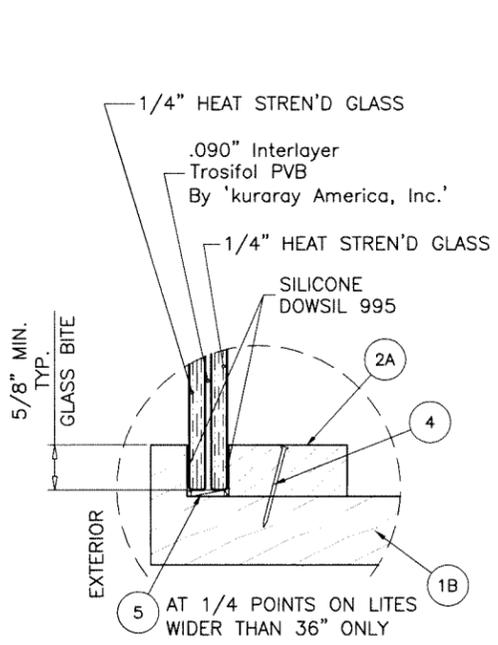

GLASS TYPE 'A'
9/16" OVERALL LAM. GLASS

1-3/4" FRAMES

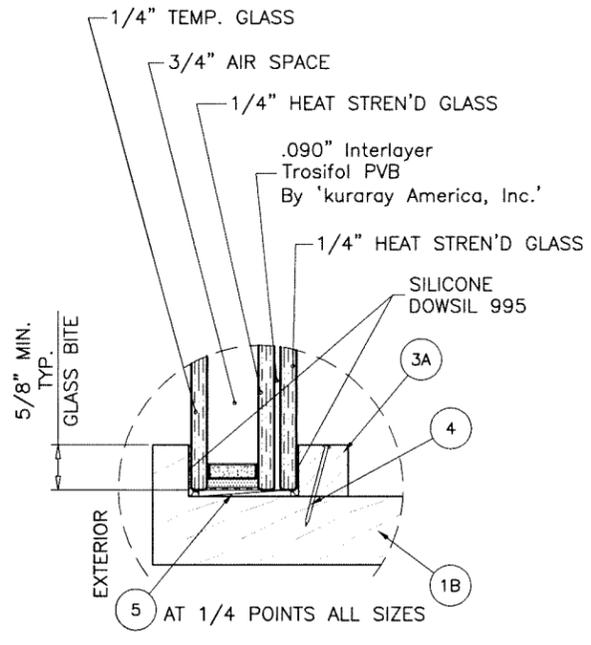

GLASS TYPE 'Ai'
1-1/2" OVERALL INSUL. LAM. GLASS

af c
AL-FAROOQ CORPORATION
ENGINEERS & PRODUCT DEVELOPMENT
9360 SUNSET DRIVE, SUITE 220
MIAMI, FLORIDA 33173
TEL. (305) 264-8100 FAX. (305) 262-6978
C.A.N. 3538

DIRECT SET FIXED WOOD WINDOW (L.M.I.)
Exclusive Wood Doors, Inc.
2000 N.W. 95Th Ave.
Doral, FL. 33172
Tel. (305) 477-2278 Fax. (305) 477-7140

| revisions: | no | date | by | description |
|------------|----|------|----|-------------|
| | | | | |

date: 06-06-22
scale: 3/8" = 1"
dr. by: TARIQ
chk. by:

drawing no.
22-19F
sheet 4 of 9

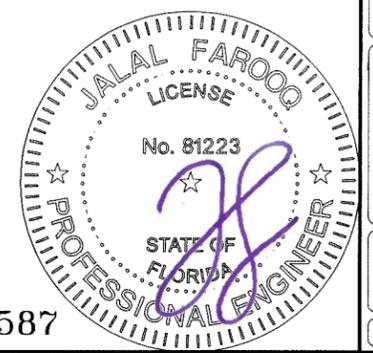

Sealed: 6/27/2022

FL #41587

COMP-ANL\22-19F-EWD

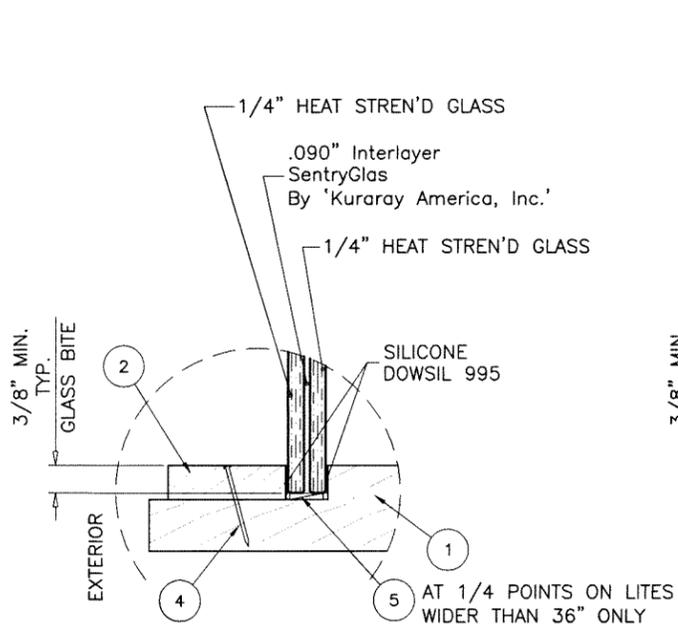

GLASS TYPE 'B'
9/16" OVERALL LAM. GLASS

1-1/4" FRAMES

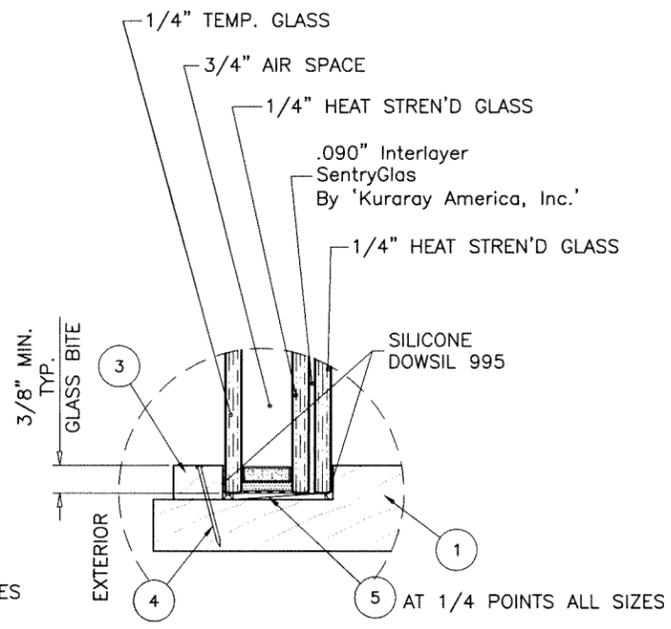

GLASS TYPE 'Bi'
1-1/2" OVERALL INSUL. LAM. GLASS

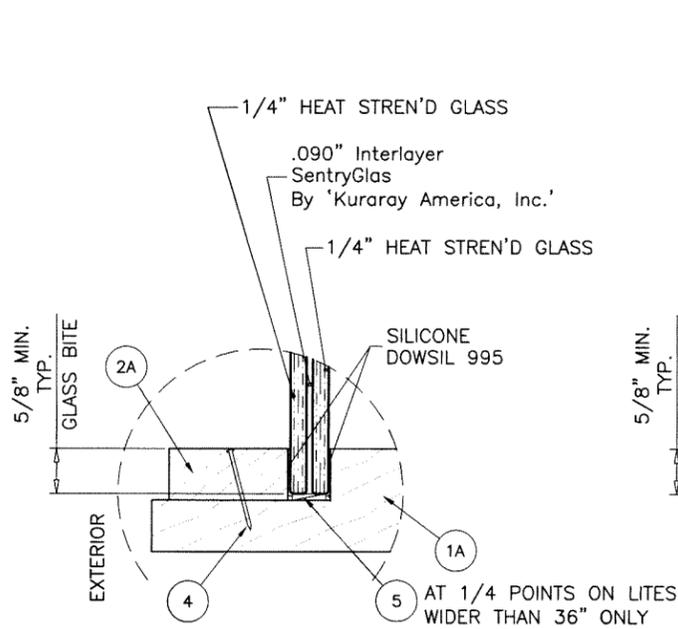

GLASS TYPE 'B'
9/16" OVERALL LAM. GLASS

1-1/2" FRAMES

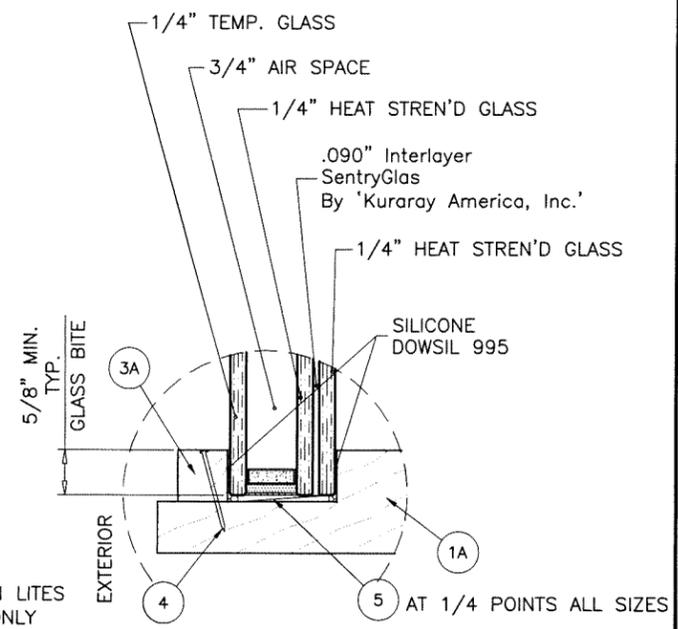

GLASS TYPE 'Bi'
1-1/2" OVERALL INSUL. LAM. GLASS

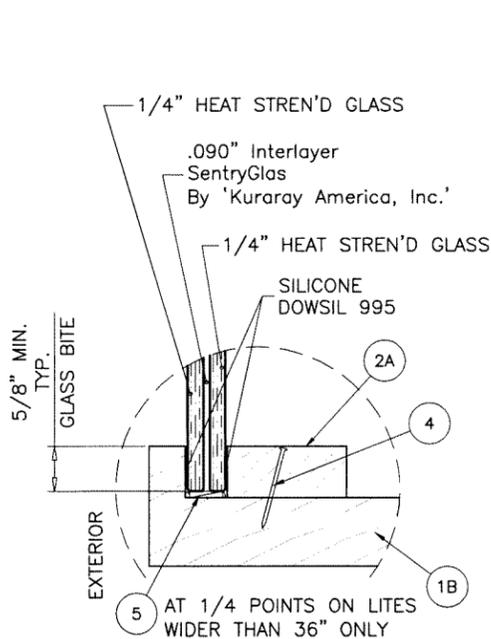

GLASS TYPE 'B'
9/16" OVERALL LAM. GLASS

1-3/4" FRAMES

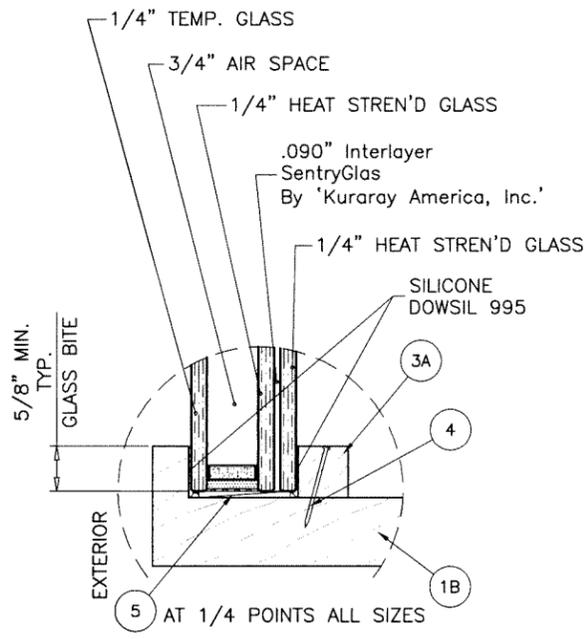

GLASS TYPE 'Bi'
1-1/2" OVERALL INSUL. LAM. GLASS

af c
AL-FAROOQ CORPORATION
ENGINEERS & PRODUCT DEVELOPMENT
9360 SUNSET DRIVE, SUITE 220 (C.A.N. 3538)
MIAMI, FLORIDA 33173 TEL. (305) 262-6978
FAX. (305) 264-8100

DIRECT SET FIXED WOOD WINDOW (L.M.I.)
Exclusive Wood Doors, Inc.
2000 N.W. 95Th Ave.
Doral, FL. 33172
Tel. (305) 477-2278 Fax. (305) 477-7140

| revisions: | no | date | by | description |
|------------|----|------|----|-------------|
| | | | | |
| | | | | |
| | | | | |
| | | | | |

date: 06-06-22
scale: 3/8" = 1"
dr. by: TARIQ
chk. by:

drawing no.
22-19F

sheet 5 of 9

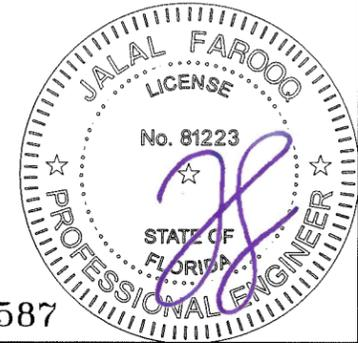

Sealed: 6/27/2022

FL #41587

COMP-ANL\22-19F-EWD

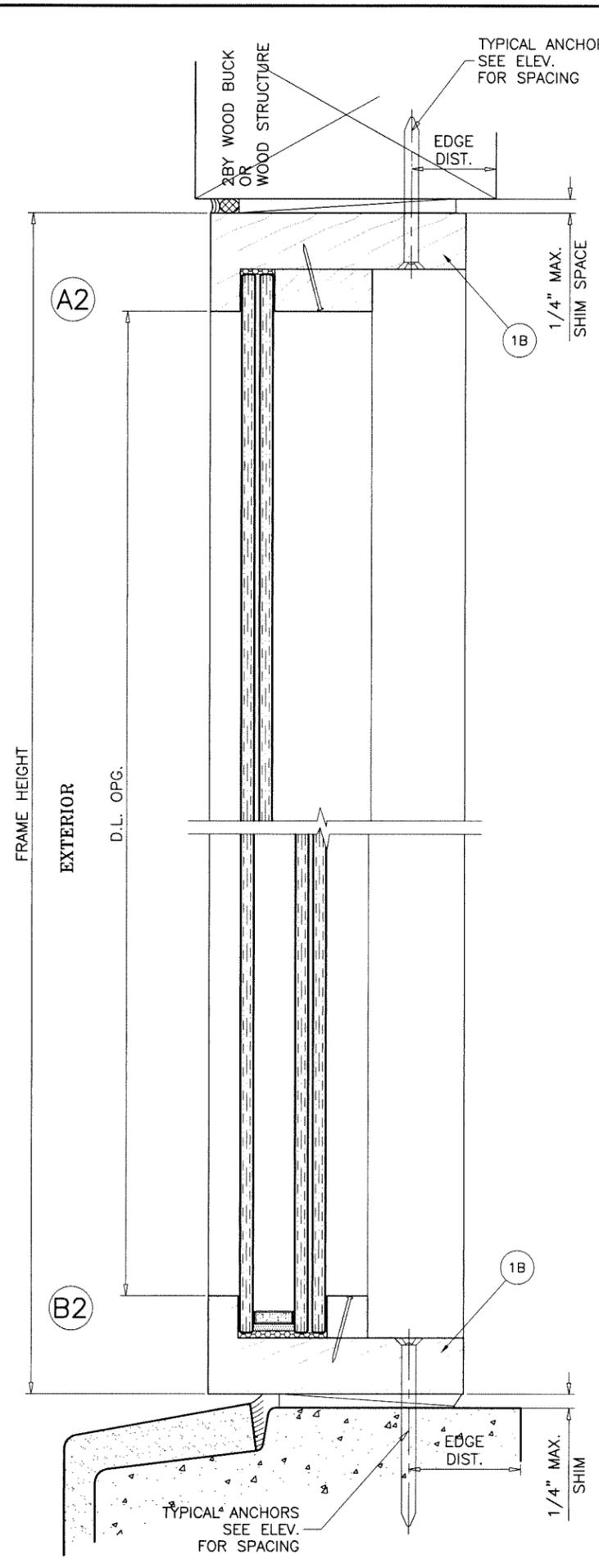
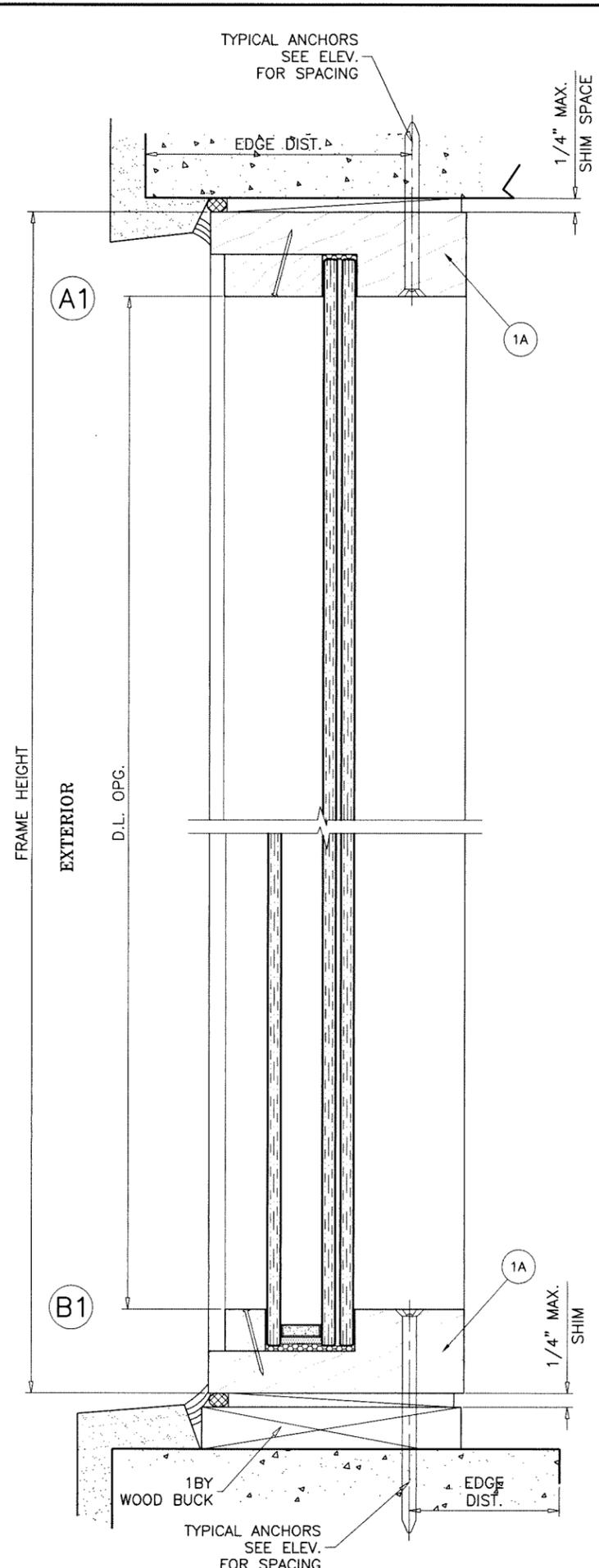
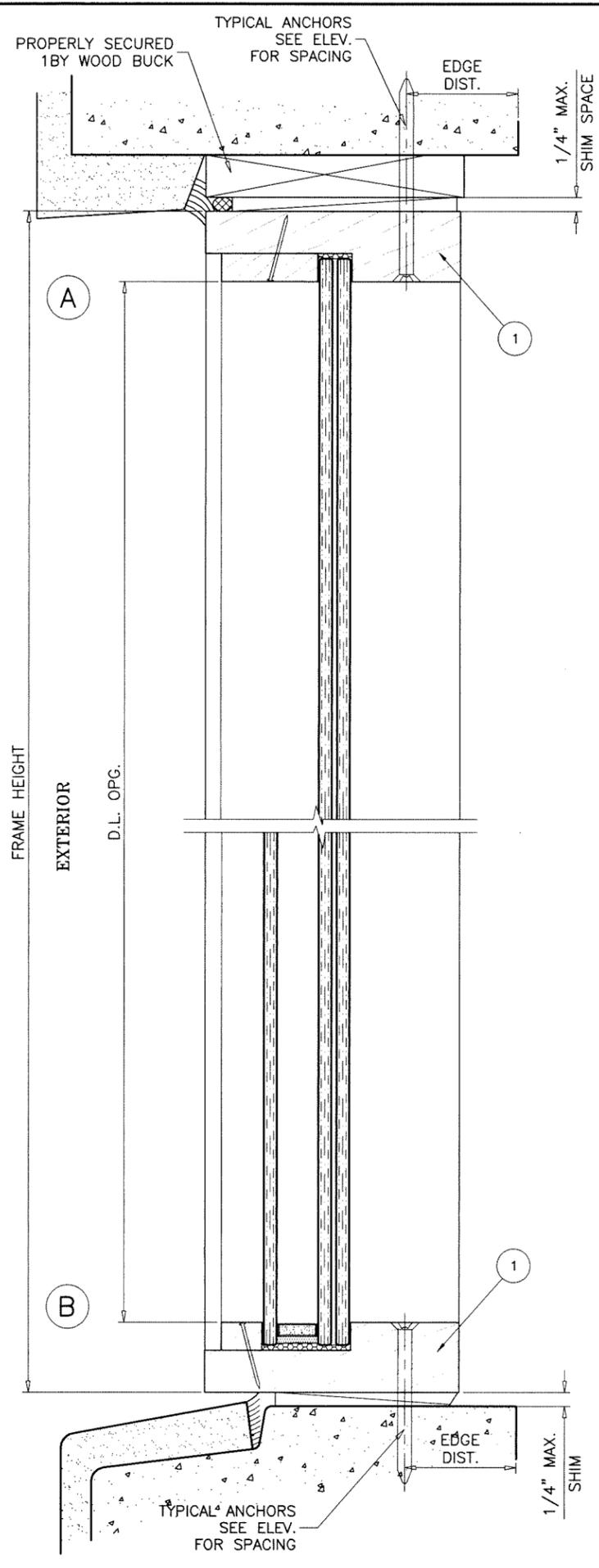

Sealed: 6/27/2022

FL #41587



af c
AL-FAROOQ CORPORATION
 ENGINEERS & PRODUCT DEVELOPMENT
 9360 SUNSET DRIVE, SUITE 220 (C.A.N. 3538)
 MIAMI, FLORIDA 33173
 TEL. (305) 264-8100 FAX. (305) 262-6978
 COMP-ANL\22-19F-EWD

DIRECT SET FIXED WOOD WINDOW (L.M.I.)
Exclusive Wood Doors, Inc.
 2000 N.W. 95Th Ave.
 Doral, FL, 33172
 Tel. (305) 477-2278 Fax. (305) 477-7140

| revisions: | no | date | by | description |
|-------------|-----------|------|----|-------------|
| date: | 06-06-22 | | | |
| scale: | 3/8" = 1" | | | |
| dr. by: | TARIQ | | | |
| chk. by: | | | | |
| drawing no. | 22-19F | | | |
| sheet | 6 of 9 | | | |

1BY OR 2BY WOOD BUCKS AND METAL STRUCTURE NOT BY 'EXCLUSIVE WOOD DOORS' MUST SUSTAIN LOADS IMPOSED BY GLAZING SYSTEM AND TRANSFER THEM TO THE BUILDING STRUCTURE.

TYPICAL ANCHORS: SEE ELEV. FOR SPACING

TYPE 'A' - **#14 WOOD SCREWS** (GRADE 2 CRS)
 INTO 2BY WOOD BUCKS OR WOOD STRUCTURES
 1-1/2" MIN. PENETRATION INTO WOOD (HEAD/SILL/JAMBS)

TYPE 'B' - **1/4" DIA. TAPCON BY 'ITW'** (Fu=125 KSI, Fy=100 KSI)
1/4" DIA. ULTRACON+ BY 'DEWALT' (Fu=164 KSI, Fy=148 KSI)
 INTO 2BY WOOD BUCKS OR WOOD STRUCTURES
 1-1/2" MIN. PENETRATION INTO WOOD (HEAD/SILL/JAMBS)

THRU 1BY BUCKS INTO CONC. OR BLOCKS
 1-1/4" MIN. EMBED INTO CONCRETE (HEAD/SILL/JAMBS)
 1-1/4" MIN. EMBED INTO BLOCKS (JAMBS)

DIRECTLY INTO CONCRETE OR BLOCKS
 1-1/4" MIN. EMBED INTO CONCRETE (HEAD/SILL/JAMBS)
 1-1/4" MIN. EMBED INTO BLOCKS (JAMBS)

TYPE 'C' - **1/4" DIA. TEKS OR SELF-DRILLING SCREWS** (GRADE 5 CRS)
 INTO F.B.C. APPROVED MULLIONS
 OR
 INTO METAL STRUCTURES (HEAD/SILL/JAMBS)
 (3) THREADS MIN. TO EXTEND BEYOND METAL THICKNESS
 ALUMINUM: 1/8" THK. MIN. (6063-T5 MIN.)
 STEEL: 1/8" THK. MIN. (Fy = 36 KSI MIN.)
 (STEEL IN CONTACT WITH ALUMINUM TO BE PLATED OR PAINTED)

CRITICAL EDGE DISTANCE

INTO CONCRETE AND BLOCKS = 2" MIN.
 INTO WOOD STRUCTURE = 1" MIN.
 INTO METAL STRUCTURE = 3/4" MIN.

WOOD AT HEAD, SILL OR JAMBS SG = 0.55 MIN.
 CONCRETE AT HEAD, SILL OR JAMBS f'c = 3000 PSI MIN.
 C-90 HOLLOW/FILLED BLOCK AT JAMBS f'm = 2000 PSI MIN.

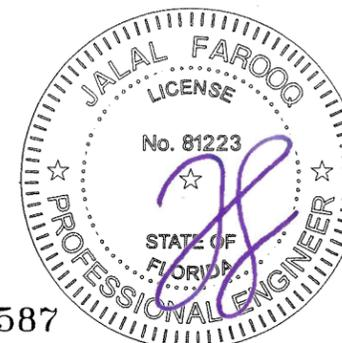
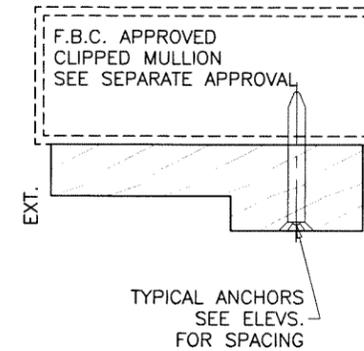
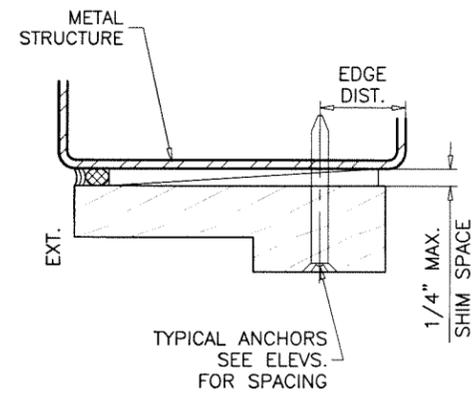

Sealed: 6/27/2022

FL #41587

af c
AL-FAROOQ CORPORATION
 ENGINEERS & PRODUCT DEVELOPMENT
 9360 SUNSET DRIVE, SUITE 220 (C.A.N. 3538)
 MIAMI, FLORIDA 33173
 TEL. (305) 264-8100 FAX. (305) 262-6978
 COMP-ANL \ 22-19F-EWD

DIRECT SET FIXED WOOD WINDOW (L.M.I.)
Exclusive Wood Doors, Inc.
 2000 N.W. 95Th Ave.
 Doral, FL. 33172
 Tel. (305) 477-2278 Fax. (305) 477-7140

| revisions: | no | date | by | description |
|------------|----|------|----|-------------|
| | | | | |
| | | | | |
| | | | | |
| | | | | |

date: 06-06-22
 scale: 3/8" = 1"
 dr. by: TARIQ
 chk. by:

drawing no.
22-19F
 sheet 7 of 9

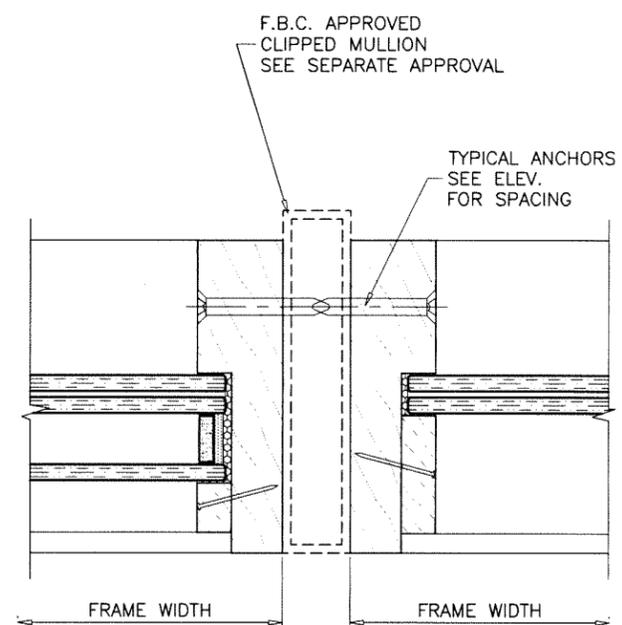
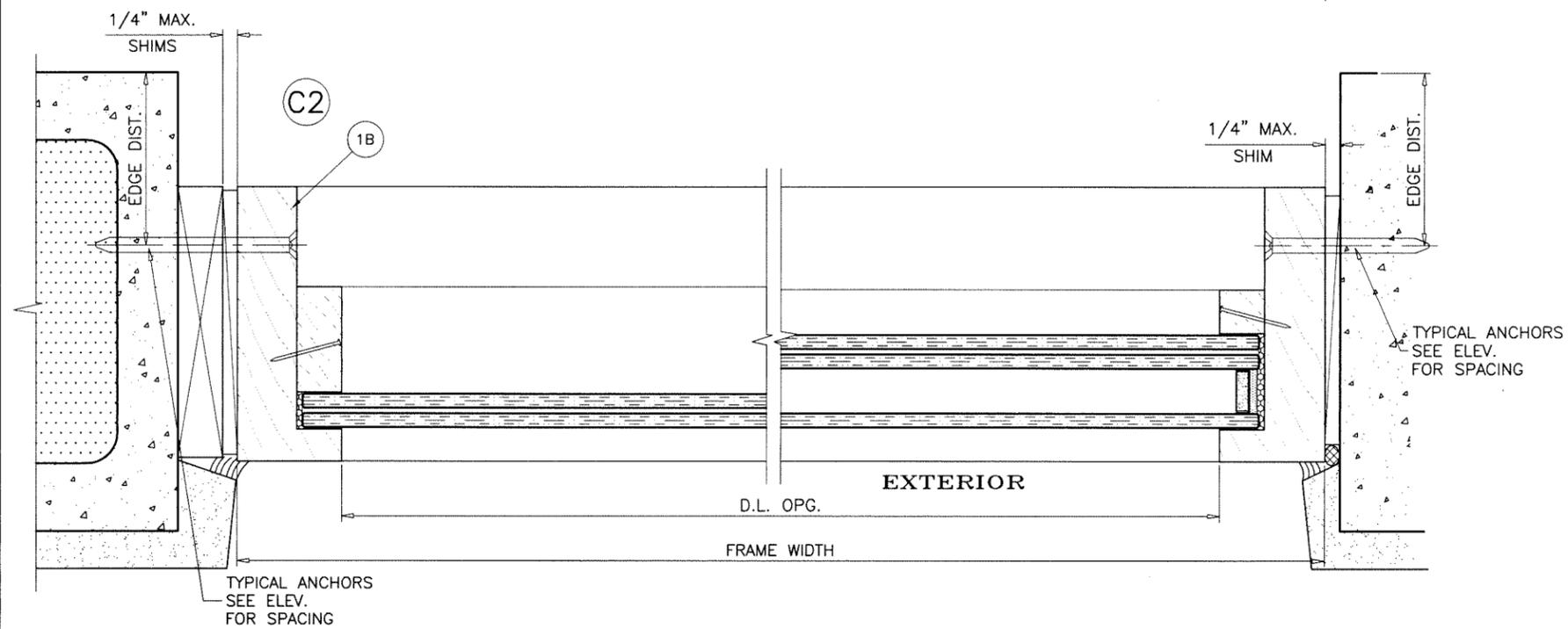
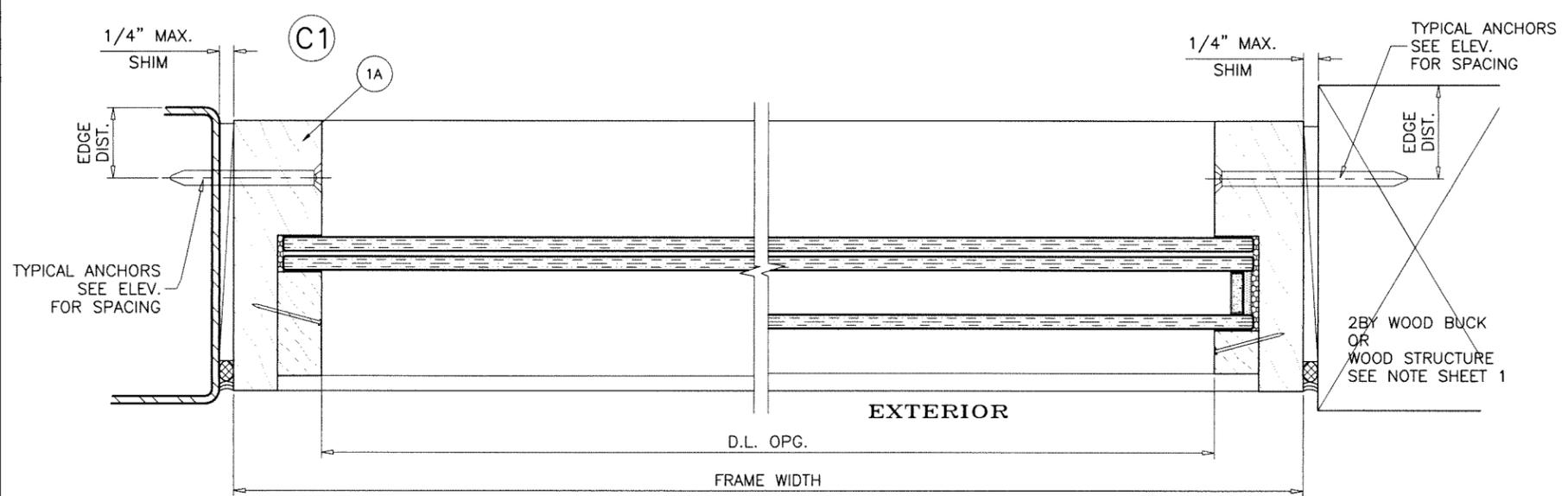
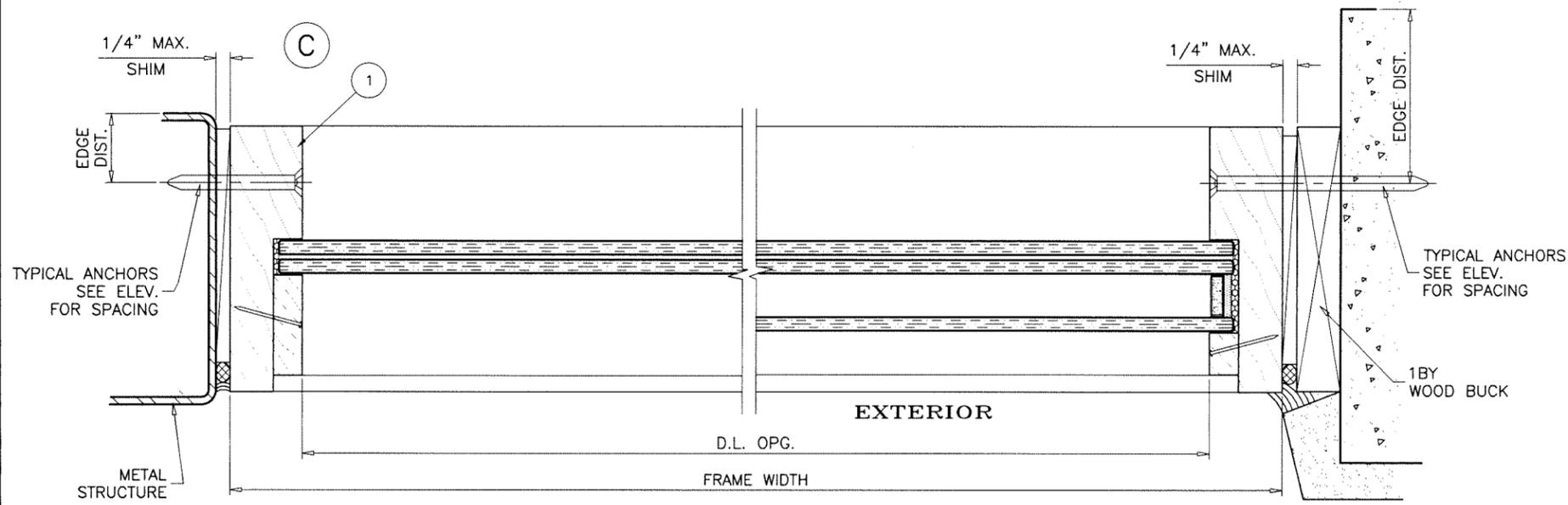

Sealed: 6/27/2022

FL #41587

af c
AL-FAROOQ CORPORATION
ENGINEERS & PRODUCT DEVELOPMENT
9360 SUNSET DRIVE, SUITE 220 (C.A.N. 3538)
MIAMI, FLORIDA 33173
TEL. (305) 264-8100 FAX. (305) 262-6978
COMP-ANL\22-19F-EWD

DIRECT SET FIXED WOOD WINDOW (L.M.I.)
Exclusive Wood Doors, Inc.
2000 N.W. 95Th Ave.
Doral, FL. 33172
Tel. (305) 477-2278 Fax. (305) 477-7140

| revisions: | no | date | by | description |
|-------------|----------|----------|-----------|-------------|
| date: | 06-06-22 | scale: | 3/8" = 1" | |
| dr. by: | TARIQ | chk. by: | | |
| drawing no. | 22-19F | | | |
| sheet | 8 of 9 | | | |

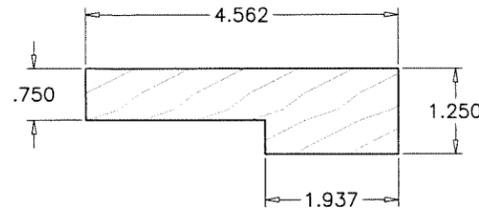

1 1-1/4" FRAME HEAD/SILL/JAMB

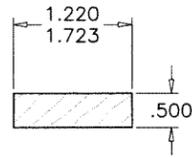

2 GLASS STOP (LAM. GLASS)

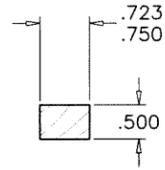

3 GLASS STOP (INSUL. LAM. GLASS)

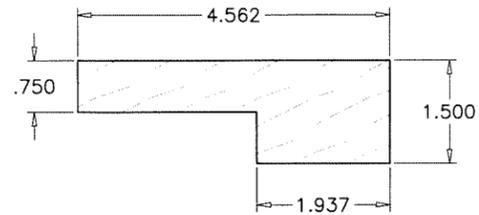

1A 1-1/2" FRAME HEAD/SILL/JAMB

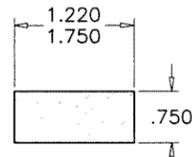

2A GLASS STOP (LAM. GLASS)

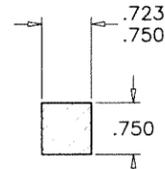

3A GLASS STOP (INSUL. LAM. GLASS)

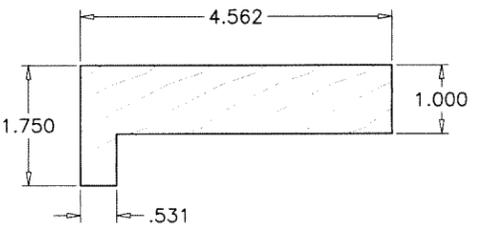

1B 1-3/4" FRAME HEAD/SILL/JAMB

| ITEM # | PART # | REQD. | DESCRIPTION | MATERIAL | MANF./SUPPLIER/REMARKS |
|--------|--------|----------|-------------------------------------|----------|----------------------------|
| 1 | - | 4 | 1-1/4" FRAME HEAD/SILL/JAMB | WOOD | MAHOGANY |
| 1A | - | 4 | 1-1/2" FRAME HEAD/SILL/JAMB | WOOD | MAHOGANY |
| 1B | - | 4 | 1-3/4" FRAME HEAD/SILL/JAMB | WOOD | MAHOGANY |
| 2 | - | 4/ WDW. | 1/2" GLASS STOP (LAM. GLASS) | WOOD | MAHOGANY |
| 2A | - | 4/ WDW. | 3/4" GLASS STOP (LAM. GLASS) | WOOD | MAHOGANY |
| 3 | - | 4/ WDW. | 1/2" GLASS STOP (INSUL. LAM. GLASS) | WOOD | MAHOGANY |
| 3A | - | 4/ WDW. | 3/4" GLASS STOP (INSUL. LAM. GLASS) | WOOD | MAHOGANY |
| 4 | - | AS REQD. | 18 GA. X 1-1/4" BRAD NAILS | - | AT 6" FROM ENDS & 12" O.C. |
| 5 | - | AS REQD. | SETTING BLOCKS AT 1/4 POINTS | EPDM | DUROMETER 80±5 SHORE A |

TYPICAL WOOD MAHOGANY LUMBER
 SPECIFIC GRAVITY = 0.44 MIN.
 GRADE = 2 MIN.
 MOISTURE CONTENT = 19% MAX.

SEALANTS:

ALL JOINTS AND FRAME CONNECTIONS SEALED WITH SILICONE.

AL-FAROOQ CORPORATION
 ENGINEERS & PRODUCT DEVELOPMENT
 9360 SUNSET DRIVE, SUITE 220
 MIAMI, FLORIDA 33173
 TEL. (305) 264-8100 FAX. (305) 262-6978
 (C.A.N. 3538)

DIRECT SET FIXED WOOD WINDOW (L.M.I.)

Exclusive Wood Doors, Inc.
 2000 N.W. 95Th Ave.
 Doral, FL. 33172
 Tel. (305) 477-2278 Fax. (305) 477-7140

| revisions: | no | date | by | description |
|------------|----|------|----|-------------|
| | | | | |

date: 06-06-22
 scale: 3/8" = 1"
 dr. by: TARIQ
 chk. by:

drawing no.

22-19F

sheet 9 of 9



Sealed: 6/27/2022

FL #41587

COMP-ANL\22-19F-EWD